

MTS Jack and Bore Design Criteria

Note: For the purposes of this Design Criteria and subsequent Construction Notes, the term “Jack and Bore” is used generically to refer to several trenchless construction methods – a few of which are described in these notes. The limitations of these notes do not preclude the use of other trenchless construction methods, provided they are approved by MTS.

The basic guidelines to be followed for Jack and Bore Design are referenced in the AREMA (American Railway Engineering and Maintenance of Way Association) Manual. As an MTS supplement to the AREMA, the following standards and design criteria shall also apply:

1. All underground utilities under railroad tracks shall be encased in a larger pipe or conduit called the “casing pipe.”
2. Installation of casing pipes by open trench is prohibited unless approved by MTS.
3. Casing pipe shall be installed across the entire width of the railroad right-of-way and shall extend beyond the right-of-way a minimum of 10 feet unless otherwise approved by MTS.
4. The top of casing shall have a minimum depth of 5.5 feet below the top of tie and a minimum depth 3 feet below ground surface including bottom of ditches and other low points within the railroad right-of-way.
5. All casing pipes shall be installed with a minimum slope of 1% unless otherwise approved by MTS and/or otherwise approved by other jurisdictional design criteria.
6. Steel casing pipes shall comply with AREMA Chapter 1, Part 5, including a specified minimum yield strength, SMYS, of at least 35,000 psi (241,317 kPa) and a wall thickness that meets or exceeds Table 1-5-2, Minimum Wall Thickness for Steel Casing Pipe. For all other casing pipes, the Engineer/Contractor shall submit to MTS for review, load calculations for the proposed casing with applied load as defined by Cooper E-80 with a 50% added impact load. The calculations shall be signed and stamped by a California licensed Civil or Structural Engineer.
7. Provide a completed Plan Data Table per AREMA Chapter 1, Part 5. For pipes installed via Horizontal Directional Drilling, provide minimum, maximum, and operating drilling head fluid pressures for the pilot bore and back ream operations.

Geotechnical Investigation

1. General Requirements:

- a. Test borings or other soil investigations, analysis, and recommendations, approved by MTS, shall be made to determine the nature of the underlying material for all pipe crossings with casing pipe sizes greater than or equal to 24 inches in diameter under track(s) and where the casing pipe depth is 15 feet or less below the base of rail elevation.
- b. Test borings or other soil investigations, analysis, and recommendations approved by MTS, may be required when, in the judgment of MTS, they are necessary to determine the adequacy of the design and construction of pipe crossings with casings less than 24 inches in diameter or greater than 15 feet below the base of rail elevation and for other facilities located on the right-of-way. Note: The Permittee shall be responsible for locating all underground utilities including MTS signal and traction power cables.

2. Location:

- a. At a minimum, geotechnical borings shall be performed on each side of the track(s), on the centerline of the pipe crossing, and as close to the track(s) as practicable. The locations of the borings must be confirmed and finalized by the project Geotechnical Engineer of Record (GEOR). Entering MTS property for the purpose of conducting borings requires a Right of Entry permit.
- b. Test boring logs shall be accompanied with a plan, drawn to scale, showing the location of the borings in relation to the track(s) and the proposed pipe, the elevation of the ground surface at each boring, and the elevation of the base of rail of the track(s). Elevations shall be shown to the nearest 0.1 ft.

3. Sampling:

- a. Test borings shall be performed and logged in accordance with USCS and ASTM standards under supervision of the GEOR. Disturbed or Undisturbed samples must be collected utilizing appropriate sampling techniques such as the Standard Penetration Test, Modified California sampler, Shelby tube or others depending on the soils encountered. Effort shall be made to collect continuous sampling to a minimum depth of 1.5 times the casing diameter below the proposed utility invert elevation or a minimum of 10 feet

below invert elevation. If bedrock is encountered within the termination depth, efforts must be made to obtain rock samples using coring techniques with core runs not to exceed 5ft in length. Documentation of early refusal and any unusual conditions must be made during field logging.

- b. Accurate reading of ground water table (during drilling and static) must be documented.
- c. All borings shall be sealed for their full depth in accordance with County/Water district guidelines as required per the permit.
- d. Soil samples taken from auger vanes or return washwater are not acceptable.
- e. Samples shall be retained for review by MTS if requested for at least 6 months.

4. Laboratory Testing:

- a. Upon completion of visual classification, samples must be stored and transported properly to the laboratory. Lab testing must be assigned by the GEOR to identify soil classification and determine strength parameters as appropriate for the design and evaluation. At a minimum moisture density, gradation, Atterberg limits and strength tests shall be performed.

5. Boring Logs:

- a. Test boring logs shall clearly indicate all of the following:
 - i. Boring number as shown on the required boring location plan.
 - ii. Ground elevation at each boring using same datum as the pipeline construction plans.
 - iii. Sampling type, depth and percent recovery of all soil samples.
 - iv. Depth from surface for each change in strata.
 - v. Soil/Rock classification
 - vi. Blows for every 6 inches of penetration for the SPT sampling, consistency based on blows/ft, modification

factors if alternate to SPT is used in sampling, and other description shall be included.

vii. Percent recovery and Rock Quality Designation (RQD) for all rock cores.

viii. Depth to ground water while sampling and when it has stabilized in the bore hole.

ix. Failed boring attempts shall be logged and reported.

b. The location of the carrier pipe and/or casing pipe shall be superimposed on the boring logs before submission to MTS.

6. Geotechnical Recommendations and Reporting:

a. Boring logs and soil data shall be accompanied by an analysis of the pertinent soil characteristics and their impact on the project as it relates to the railway by a certified Geologist or licensed Professional Engineer.

b. The geotechnical report shall include:

i. Summary of field investigation.

ii. Summary of laboratory testing data

iii. Boring logs and location with respect to the proposed utility elevation

iv. Summary of subsurface conditions encountered within the Utility layout and suitability of soils for installation methods.

v. Analysis and Evaluation of response of soils during and after installation of jack and bore conduit. This includes but not limited to settlement under the tracks, any potential ground loss or subsidence, and ground water management.

vi. Recommendations including:

1. Short-term and long-term settlement estimation due to utility installation under the track.

2. Plan for a procedure to prevent failure and a potential collapse during casing pipe installation.

3. Hydrostatic uplift pressures, if applicable.
 4. Minimum depth of cover under the tracks.
 5. Soil pressures exerted on top of the pipe to evaluate minimum pipe diameter.
 6. Dewatering recommendations.
 7. Recommendations for risk mitigation measures for potential loss of drilling fluid or frac-out during directional drilling operations.
 8. Slope Stability evaluation and recommendations.
- c. For projects that propose to use Horizontal Directional Drilling (HDD) for casing pipe installation, the geotechnical report shall assess the risk of frac-out. Information required to evaluate such a risk includes but not limited to the following:
- i. Maximum allowable fluid pressure
 - ii. Minimum depth of bore
 - iii. Expected drilling fluid pressure
 - iv. Pressure exerted by overburden
 - v. Potential for type of soil to have fissures
- d. The geotechnical report must be reviewed and approved by MTS as a condition of plan review acceptance. MTS reserves the rights, based on test results and recommendations provided, to require the Permittee to select an alternate utility crossing location, or to require additional engineering specifications to be implemented, at the sole expense of the Permittee, to utilize the originally proposed utility crossing location.

MTS Jack and Bore Construction Notes

General

1. See MTS Standard Construction Notes for additional requirements.
2. For pipelines carrying flammable or hazardous materials, the Contractor shall

adhere to AREMA and regulatory agency guidelines.

3. The Contractor shall obtain all permits necessary for the proposed project including but not limited to encroachment, SWPPP, and environmental permits, and third-party utility permits.
4. Prior to any commencement of work, the Contractor shall submit to MTS for review and approval, an updated description of the work process including all plan and field changes/modifications, certificates of compliance, and scheduled activities for work affecting railroad right-of-way.
5. Prior to any commencement of work, the Contractor shall submit to MTS for review and approval, shoring drawings and calculations. All drawings and calculations shall be signed and stamped by a Civil or Structural Engineer licensed in the State of California.
6. The Contractor shall verify and mark out all railroad right of way limits and property entitlements (easements, license agreements, etc.) within the vicinity of the work and/or related to the work.
7. Prior to any commencement of work, the Contractor shall layout the proposed jacking and receiving pits for MTS inspection and acceptance. Both pits shall be constructed outside of the railroad right-of-way unless otherwise approved by MTS.
8. The Contractor shall monitor rail elevations prior to, during, and immediately after the Jack and Bore operation. Both rails of each track shall be monitored at the point of crossing and at 10' and 20' out in each direction, from the crossing point, unless otherwise directed by MTS. Monitoring points shall be marked to ensure repeatability of measurements. Top of rail elevations shall be recorded with an accuracy of one (1) one-hundredth of a foot (0.01') and shall be submitted to MTS for review within 24 hours of the measurement being taken. Survey data shall be tabulated so that elevations at each monitoring point can be easily compared against the baseline elevations as work progresses. Surveys shall be conducted:
 - a. Prior to construction to establish a baseline, no greater than 2 weeks before start of construction.
 - b. Three times a day for the duration of the construction. Times shall be spread uniformly during the work period.
 - c. Once per day for 1 week following 'stable' condition with completion of all construction activities. If no movement, no further monitoring is needed.

Use of targets applied to the rail and all elevations monitored from off track is encouraged.

MTS may require more frequent monitoring at certain locations such as bridge and grade crossing approaches, or locations with soft soil conditions.

9. All areas backfilled within the railroad right-of-way, or that encroach within a 2:1 downward sloping line from the edge of right-of-way, shall be at 95% relative dry compaction, within +/-2% of optimum moisture content, and in lifts not to exceed 8". Backfilling in all other areas shall be in accordance with the local jurisdiction's standards. The Contractor shall submit a compaction report prepared under the supervision of a California licensed Geotechnical Engineer.
10. The Contractor shall remove all temporary facilities constructed on the railroad right-of-way, in addition to debris, trash, and other items not originally at the site prior to construction, and shall notify MTS within 24 hours that all construction has been completed.
11. A record of utility locates must be available at the work site. Utility locates for railway utilities are not a part of the Utility One Call system and must be requested from Cable Pipe and Leak ("CPL"), with proper notification to MTS, per the MTS Standard Construction Notes prior to any work.

Jack and Bore Operations

1. Prior to any commencement of work, the Contractor shall submit to MTS for review and approval, a plan showing the proposed method of casing installation, construction access, stockpile locations, SWPPP control measures, fencing type and location, and a milestone schedule. The Contractor may utilize any one of the following methods of installing casing and shall adhere to its respective requirements:

Jacking:

- a. This method shall be in accordance with the AREMA (American Railway Engineering and Maintenance of Way Association) Manual, Volume 1, Chapter 1, Part 4, "Earth Boring and Jacking Culvert Pipe Through Fills." This operation shall be conducted without handmining ahead of the pipe and without the use of any type of boring, augering, or drilling equipment.
- b. Bracing and backstops shall be designed and jacks with sufficient rating used so that the jacking can progress without stoppage (except for adding lengths of pipe) until the leading edge of the pipe reaches the receiving pit.

- c. During jacking, an earth plug 1.5 times the diameter of the casing shall be maintained at all times. Jacking operations shall be continuous on a 24-hour per day basis while casing is within the zone of influence..

Auger Boring:

- a. This method consists of pushing the casing pipe into the earth with a horizontal auger boring machine with an auger rotating within the casing pipe to remove the spoil. The front of the casing pipe shall be provided with mechanical arrangements or devices that will prevent the auger from advancing in front of the casing so that there will be no unsupported excavation ahead of the casing. The auger and cutting head arrangement shall be removable from within the pipe in the event an obstruction is encountered. The over-cut by the cutting head shall not exceed the outside diameter of the casing pipe by more than one-half inch. The face of the cutting head shall be arranged to provide reasonable obstruction to the free flow or running of earth material.
- b. The use of water or other liquids to facilitate casing placement and/or spoil removal is prohibited.
- c. Plans and descriptions of the auger stop arrangement to be used shall be submitted to MTS for review and approval prior to commencement of work.

Note: Any method which employs simultaneous boring and jacking or drilling and jacking for pipes over 8 inches in diameter that does not adhere to the above requirements will not be permitted. For casing pipes 8 inches and smaller in diameter, augering or boring without the same requirements may be considered if approved by MTS.

Horizontal Directional Drilling (for casings 12" in diameter or less)

- a. This method consists of utilizing specialized drilling equipment to bore a small diameter pilot hole along the desired alignment using a mechanical cutting head with high-pressure bentonite slurry to remove the cuttings. The drill string is advanced with the bentonite slurry pumped through the string to the cutting head and then forced back along the string, carrying the cuttings back to the surface for removal. After the cutting head reaches the far side of the crossing, it is removed and a reamer (with a diameter wider than the cutting head) is attached to the lead end of the drill string. The casing is attached to the reamer and the casing is then pulled back into its final position.

- b. Excavating the soil by means of jetting of fluid or jetting of slurry are not allowed.
 - c. Slurry use shall be kept to a minimum and shall only be used for head lubrication and/or spoils return. The Contractor shall calculate anticipated slurry use and monitor actual use during the boring operation in order to determine the slurry loss into the surrounding soil. The bentonite slurry shall seal the annular space between the casing and the excavated soil with a minimum return of 95%.
 - d. Maximum bore hole diameter will be no more than 2 inches larger than the outside diameter of the installed carrier or casing pipe.
2. Jacking and receiving pits shall be fenced on all sides and secured in compliance with OSHA requirements.
 3. All jack and bore operations within the railroad right-of-way shall be advanced in a timely manner with minimal breaks in operation and no change in crew or operator. Inspections by MTS or its designated engineering consultant shall occur before, during, and after construction. MTS may require continuous on-site inspection during any portion or the entirety of jack and bore operations at its discretion. Should work begin without the proper approvals, the work will be halted and any casing installed will be abandoned in place, pressure grouted full, and capped to the satisfaction of the MTS.
 4. Pressure grouting of the soils before or during jacking or boring may be required to stabilize the soil, control water, prevent loss of material, and prevent settlement or displacement of the ground and/or tracks. Grout shall be cement, chemical, or other special injection material selected to accomplish the necessary stabilization. The grouting contractor shall be a specialist in the field with a minimum of 5 years continuous experience of successfully grouting soil. Materials to be used and the method of injection shall be prepared by a California licensed Geotechnical Engineer, or by an experienced and qualified company specializing in this work and submitted for approval by MTS prior to the commencement of work. Proof of experience and competency shall accompany the submission.
 5. Bored or jacked installations shall have a bored-hole diameter essentially the same as the outside diameter of the casing plus the thickness of the protective coating. If voids should develop or if the bored-hole diameter is greater than the outside diameter of the casing pipe, plus coating, by more than approximately 1 inch, grouting or other methods as approved by MTS shall be employed to fill such voids.
 6. Casing and carrier pipes shall be constructed to prevent leakage of any

substance.

7. If an obstruction is encountered during installation of the casing pipe that will stop the forward action of the pipe, and it becomes evident that it is impossible to advance the pipe, operations will cease and the pipe shall be abandoned in-place and pressure grouted full with a 2-sack slurry before continuing with work.
8. The Contractor is responsible for analyzing the survey data from track settlement monitoring within 24 hours of each survey being completed. The Contractor must act immediately if the settlement thresholds listed below are met or exceeded. If ground or track displacement of $\frac{1}{4}$ " (Threshold) or greater compared to the baseline is detected during the installation of the casing pipe, the Contractor shall notify MTS immediately and analyze all subsequent settlement monitoring survey data immediately upon it being recorded. If displacement of $\frac{1}{2}$ " (Shutdown) compared to the baseline is detected, then all operations shall stop immediately. The contractor is liable for all damages resulting from ground or track displacement. Should the track displace, corrective action shall be taken by MTS forces or the Contractor as approved by MTS. MTS expenses shall be reimbursed by the Contractor.
9. The Contractor shall supply Contingency Plan(s), which anticipate reaching the Threshold and Shutdown values, for all construction activities which may result in horizontal and/or vertical track deflection.

Track monitoring values:

Threshold value = 1/4 inch permanent vertical or horizontal deflection

Shutdown value = 1/2 inch permanent vertical or horizontal deflection

The Contingency Plans shall provide means and methods, with options if necessary, reviewed and approved by the Geotechnical Engineer of Record (GEOR)

The Contractor should anticipate the need to implement each Contingency Plan with required materials, equipment and personnel. Once the Threshold value is met, the contractor shall determine the appropriate Contingency Plan(s) and immediately discuss this plan with and receive approval confirmation from MTS or authorized Railroad representative.

Once the Shutdown value is met all project work shall stop and the chosen Contingency Plan shall commence.

MTS may choose to allow and/or require the immediate implementation of specific approved Contingency Plans, submitted by the Contractor, once the Shutdown value is met.

10. Should ground water or other loose and unstable soils conditions be encountered during construction, the Contractor shall immediately stop work, notify the railroad inspector and flagman, provide necessary support to track and other railroad structures, and notify MTS. It shall be the responsibility of the contractor to make necessary corrections to construction process to allow for said conditions.
11. When water is known or expected to be encountered at the site, the Contractor shall adhere to the following:
 - a. The proposed methods of dewatering shall be submitted to MTS for review and approval prior to the commencement of work.
 - b. Pumps of sufficient capacity to handle the flow shall be maintained at the site and be operated on a 24-hour per day basis until the MTS inspector determines their operation can be safely halted.
 - c. The dewatering system shall lower and maintain the ground water level to a minimum of 2 feet below the invert at all times during construction by utilizing well points, vacuum well points, or deep wells to prevent the inflow of water or water and soil into the heading. Ground water observation wells may be required to demonstrate that the dewatering requirements are being complied with.
 - d. Close observation of the railroad trackway shall be maintained to detect any settlement or displacement of track, ground, or facilities.
 - e. The discharge from the dewatering operations in the vicinity of the railroad shall be carefully monitored. Should excessive fine soils particles at any time during the dewatering process be observed, the dewatering shall be halted immediately and cannot resume until the unsatisfactory condition is remedied to the satisfaction of the MTS inspector.
12. All ends of the casing pipe shall be sealed unless otherwise authorized by MTS. When casing pipes are sealed at each end, vent pipes shall be installed.
13. The Contractor shall install permanent signs identifying the location of the pipe at the edge of the railroad right-of-way unless within a public grade crossing.
14. Only pipes within the zone of influence may be abandoned in place. All other pipes to be retired within the railroad right of way must be removed. All abandoned pipes left in place shall be pressure grouted full the entire

length. Location, length, and depth of abandoned casing pipes and carrier pipes shall be shown on the as-built drawings.

15. All underground utilities constructed within railroad right-of-way or abandoned in place are subject to MTS independent inspection and acceptance.
16. The GEOR must review and approve all contractors' trenchless design submittals, construction means and methods, jacking calculations, grouting plans, dewatering methods and impacts, settlement monitoring plan and provide a signed letter of adequacy for MTS to review.
17. Potholing
 - a. General:
 - i. Clearance From Track:
 1. Potholes shall be located as far from tracks as possible. Applicant submissions must demonstrate their efforts to maximize the distance of potholes from the track.
 - ii. Size of Pothole:
 1. See Figure 1 below for allowable pothole size. Any proposed pothole greater in size shall follow the MTS Shoring Guidelines.
 - iii. All potholes within the zone of influence shall be backfilled with controlled low strength material (CLSM) or other controlled fill recommended by the GEOR and approved by MTS to prevent soft spots or any loss of support beneath the tracks.
 - b. 0 to 9 feet from track centerline:
 - i. Potholes within 9 feet from track centerline are strongly discouraged.
 1. A variance may be considered if it can be demonstrated that no other feasible option exists including non-invasive locating methods. If such a request is considered, it will be subject to increased requirements, more stringent review and extended review times.

2. Some of the increased requirements include, but are not limited to:
 - a. Pothole excavation to not exceed 12 inches diameter.
 - b. Slot trenching is not permitted. Prior to excavation, existing infrastructure shall first be located via non-invasive methods.
 - c. Potholes shall be clear of the track ballast, unless otherwise approved by the MTS.
 - d. All potholing activities, including excavation, utility identification, backfill, and CLSM set time, must be completed within a single, naturally occurring track window (i.e., the time between train movements). The duration of these windows varies by location, date and time of day. If permitted, MTS will likely require the work to take place during non-operating hours.
 - e. Construction Observation by an MTS-designated inspector is required. The permittee shall cover all construction observation costs.
 - f. Track and ground monitoring is required.
 - g. Geotechnical report may be required.
- c. 9 to 15 feet from track centerline:
 - i. Potholing is permitted; however, documentation must demonstrate that all reasonable efforts were made to perform the work farther from the track.
 - ii. Pothole excavation shall not exceed 18 inches x 4 feet, oriented such that the 18 inch dimension is parallel to the track, as illustrated in Figure 1.
 - iii. Construction Observation may be required.
 - iv. Track and ground monitoring may be required.

- v. Geotechnical report may be required.
- d. >15 feet from track centerline:
- i. Potholing is permitted; documentation must demonstrate that all reasonable efforts were made to perform the work as far from the track as possible.
 - ii. Pothole excavation shall not exceed 24 inches x 4 feet, oriented such that the 24 inch dimension is parallel to the track, as illustrated in Figure 1.
 - iii. Construction Observation may be required.
 - iv. Track and ground monitoring may be required.
 - v. Geotechnical report may be required.

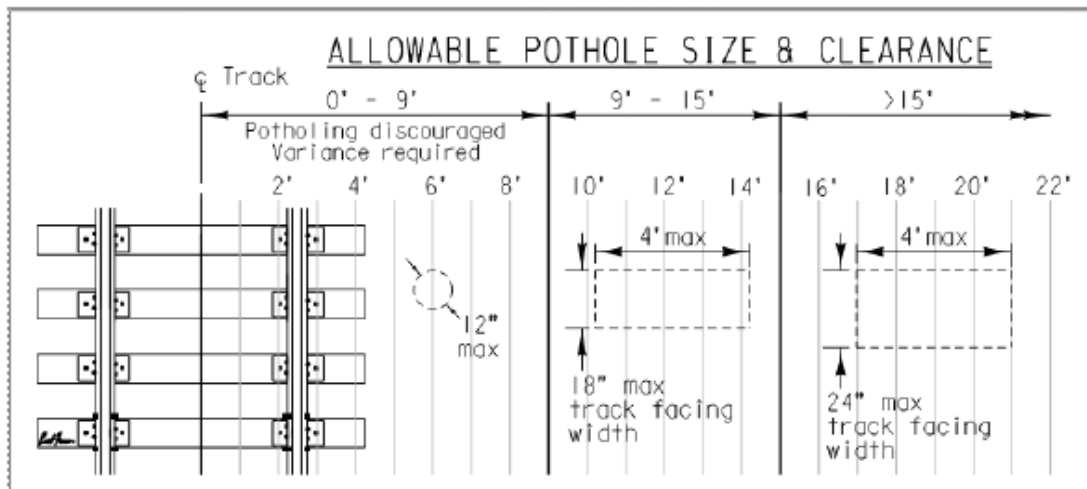

Figure 1